



I N S T R U C T I O N M A N U A L

KWM1900

Wireless microphone system

M A N U A L V E R S I O N 2 . 0
2 2 - 1 1 - 1 1

Uses future proof frequencies
UHF 863.00 - 865.00MHz frequency band
SMT technology
Preset 16 channel PLL system
Frequency stabilisation: $< \pm 30$ ppm
Dynamic range: > 100 dB
Total harmonic distortion: $< 0.5\%$
Frequency response: 40Hz-15KHz ± 3 dB
Power consumption: 100mA
Signal to noise ratio: > 100 dB
Image & spurious rejection: > 80 dB
Border upon channel rejection: > 80 dB
Receiving sensitivity: 5dBuV (SINAD=30dB)
De-emphasis: 50us

4 different Kam KWM1900 kits available:

Hand held mic system | Wireless headset system | Bodypack system | Instrument/guitar bug system

For the latest instruction manual updates and information on the entire Kam range visit:

www.kam.co.uk

Kam products are manufactured by: **Lamba plc**, Unit 1, Southfields Road, Dunstable, Bedfordshire, United Kingdom LU6 3EJ
Telephone: (+44) (0)1582 690600 • Fax: (+44) (0)1582 690400 • Email: mail@lambaplc.com • Web: www.lambaplc.com

If this product is ever no longer functional please take it to a recycling plant for environmentally friendly disposal.

Due to continuous product development, specifications and appearance are subject to change. © Copyright Lamba plc 2011. E&OE.

Thank you for purchasing this Kam product, we are sure that it will serve you for many years to come.

To optimise the performance of this product, please read these operating instructions carefully to familiarise yourself with the basic operations of this unit. Please retain them for future reference.

This unit has been tested at the factory before being shipped to you.

To prevent or reduce the risk of electrical shock or fire, do not expose the unit to rain or moisture. To prevent a fire hazard, do not expose the unit to any naked flame sources. Unplug this apparatus during lightning storms or if it is unlikely to be used for long periods of time.

When installing the unit, please ensure you leave enough space around the unit for ventilation. Slots and openings in the unit are provided for ventilation to ensure reliable operation of the product and to protect it from overheating. To prevent fire hazard, the openings should never be blocked or covered.

Always handle the power cable by the plug. Never pull out the plug by pulling on the cable. Never touch the power cable when your hands are wet as this could cause an electric shock. Do not tie a knot in the cable. The power cable should be placed such that it is not likely to be stepped on. A damaged power cable can cause a fire or give you an electrical shock. Check the power cord periodically, if you ever find that it is damaged, replace it before using the unit again. Contact your retailer for a replacement.

The voltage of the available power supply differs according to country or region. Be sure that the power supply voltage of the area where this unit is to be used meets the required written on the unit.



The lightning flash symbol inside a triangle is intended to alert the user to the presence high voltage within the unit's enclosure that may be of sufficient power to constitute a risk of electrical shock to persons.

Caution: to prevent the risk of electric shock, do not attempt to open the unit. No user-serviceable parts inside. Refer all servicing to qualified service personnel.

The exclamation mark inside a triangle is intended to alert the user to the presence of important operating and maintenance instructions in the literature accompanying the appliance.

Any modification carried out on the unit may invalidate the unit's warranty.

If applicable, only use the stand, tripod or bracket specified or sold with the apparatus.

Select the installation location of your unit carefully. Avoid placing it in direct sunlight or locations subject to vibration and excessive dust. Do not use the unit where there are extremes in temperature (below 41°F / 5°C or exceeding 95°F / 35°C).

Unpacking and safety: Please unpack your new product carefully, your new product should reach you in perfect condition. Please check that no damage has occurred during transit. If any damage is found, do not operate your unit. Please contact the retailer you purchased it from immediately. If there is any damage to the mains cable do not use the device. Always disconnect the unit from the mains supply when carrying out any servicing or cleaning of the unit.

The serial number for this equipment should be located on the rear or underside of the unit. Please make a note of this number as you will need it for your warranty, it is a good idea to keep a copy of the serial for your own records.

Kam KWM1900 features

Uses the UHF 863.00 - 865.00MHz band to avert frequency interference

Automatic frequency scan searches for available frequencies

PLL system, preset 16 non-interference channels

SMT technology

The receiver uses one 1.5V AA battery

The hand held microphone uses a single 1.5V AA battery

Ideal working distance is up to 30 metres

Easy to use and portable - the receiver connects directly to an audio mixer or amp

Ideally suited for:

Aerobics instructors

Vocalists & singers

Public speakers

Zumba instructors

Dance instructors

Musicals & theatre

Schools & colleges

DJs & musicians

Auctioneers

Video & film makers

Features of the KWM1900 receiver

1. Power switch
2. Volume control
3. Antenna
4. Power supply LED indicator
5. Signal and audio indicator
6. Battery cover
7. ACT button
8. Channel select switch
9. ACT IR
10. Receiver output plug

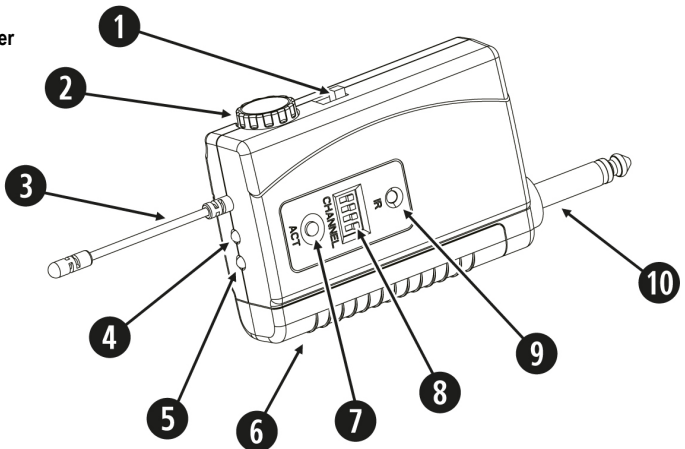



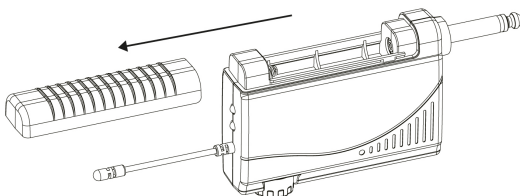













Battery compartment cover removal



Pairing the receiver with your transmitter (hand held mic or headset or bodypack or guitar bug)

1. Open the **receiver's** battery cover and insert a single 1.5 AA battery.
2. Insert the correct battery (or batteries) in the **transmitter** (hand held mic or headset or bodypack or guitar bug).
3. Switch the **receiver** ON using the power switch.
4. Choose the channel frequency you wish to use with the dipswitches on the **receiver** (see below chart).
5. Switch the **transmitter** ON using its power switch and remove any battery compartment covers that may obscure the ACT IR.
6. Press the ACT button on the **receiver** while simultaneously pointing the **receiver's** ACT IR closely towards the **transmitter's** ACT IR. Keep pressing the button until the light on the **receiver** goes green.
7. The **receiver** light will only turn green when it matches the same frequency as the **transmitter**.
8. Replace all battery compartment covers that you have removed to pair the devices.
9. The **receiver** and **transmitter** are now paired and will work together.

Channel frequency chart with dipswitch positions

CHANNEL 1 863.00 MHz  1 2 3 4	CHANNEL 2 863.40 MHz  1 2 3 4	CHANNEL 3 863.80 MHz  1 2 3 4	CHANNEL 4 864.20 MHz  1 2 3 4	CHANNEL 5 864.60 MHz  1 2 3 4	CHANNEL 6 863.20 MHz  1 2 3 4	CHANNEL 7 863.60 MHz  1 2 3 4	CHANNEL 8 864.00 MHz  1 2 3 4
CHANNEL 9 864.40 MHz  1 2 3 4	CHANNEL 10 864.80 MHz  1 2 3 4	CHANNEL 11 863.10 MHz  1 2 3 4	CHANNEL 12 863.30 MHz  1 2 3 4	CHANNEL 13 863.50 MHz  1 2 3 4	CHANNEL 14 863.70 MHz  1 2 3 4	CHANNEL 15 864.90 MHz  1 2 3 4	CHANNEL 16 865.00 MHz  1 2 3 4

When you have paired the receiver with your system's transmitter you need to plug the receiver into a mic input via the ¼ inch jack plug and set your audio level.

Hand held microphone (if supplied with your system)

Ensure that the ON switch is engaged whilst you are pairing the devices. Once paired, the mic is ready to use.

Headset microphone (if supplied with your system)

Ensure that the ON switch is engaged whilst you are pairing the devices. Once paired, the mic is ready to use. Place the headset over your ears and adjust the microphone so that is in front of your mouth.

Guitar (instrument) bug (if supplied with your system)

Ensure that the ON switch is engaged whilst you are pairing the devices. Once paired, the bug is ready to use. Insert the jack plug into the output jack socket of your guitar/instrument and adjust the volume to suit.

Bodypack (if supplied with your system)

Ensure that the ON switch is engaged whilst you are pairing the devices. Once paired, the bodypack is ready to use. Insert your chosen microphone or instrument lead into the audio socket of the bodypack and adjust the volume to suit.

Features of the KWM1900 microphone (if supplied with your system)

- 1. Grille
- 2. Power supply LED indicator
- 3. Power switch
- 4. Battery compartment cover
- 5. ACT IR
- 6. Battery compartment

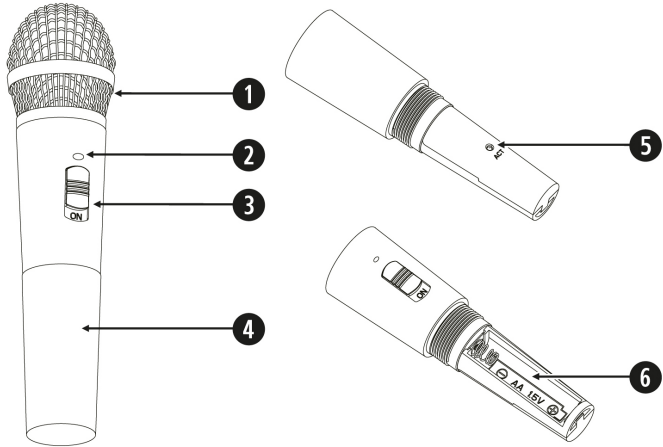

Features of the KWM1900 headset microphone (if supplied with your system)

- 1. Power switch
- 2. Antenna
- 3. ACT IR (shown with battery cover removed)
- 4. Battery compartment
- 5. Power supply LED indicator
- 6. Microphone

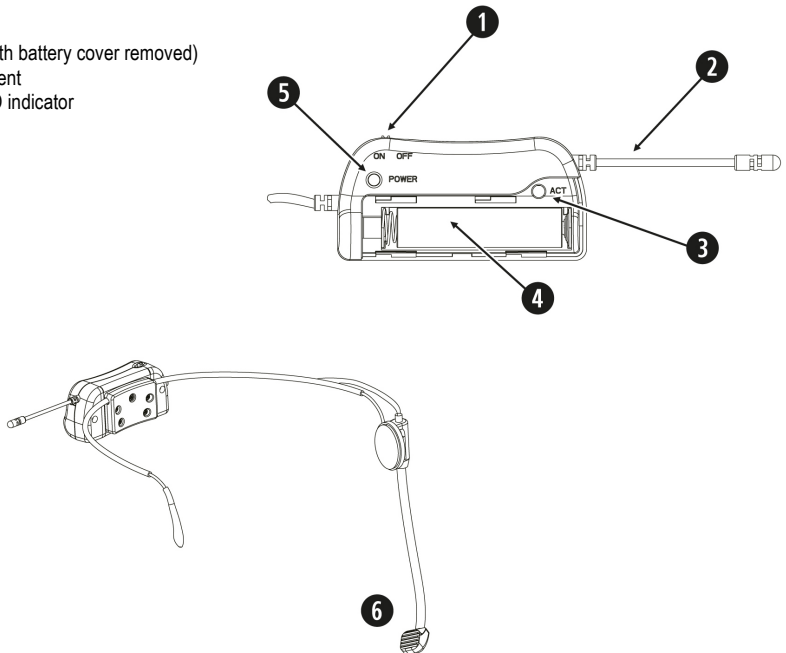

Features of the KWM1900 guitar bug (if supplied with your system)

- 1. Battery compartment
- 2. Antenna
- 3. Power switch
- 4. 15dB pad switch
- 5. ¼ inch jack instrument insert
- 6. Power supply LED indicator
- 7. ACT IR (not shown)

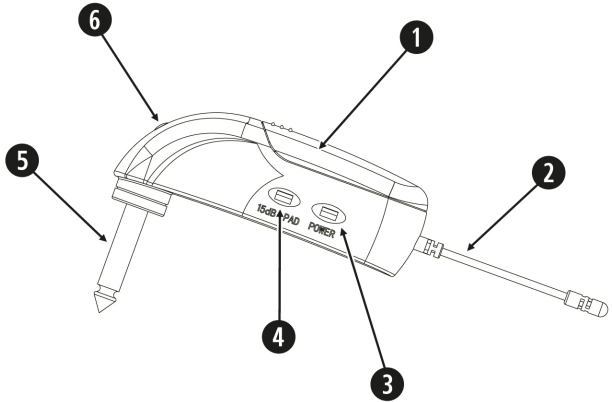

Features of the KWM1900 bodypack (if supplied with your system)

- 1. Antenna
- 2. Battery compartment
- 3. Audio/microphone input
- 4. Power supply LED indicator
- 5. Power switch
- 6. Volume control knob
- 7. ACT IR (not shown)
- 8. Lavalier microphone (not shown)
- 9. Headset microphone (not shown)
- 10. Instrument lead (not shown)

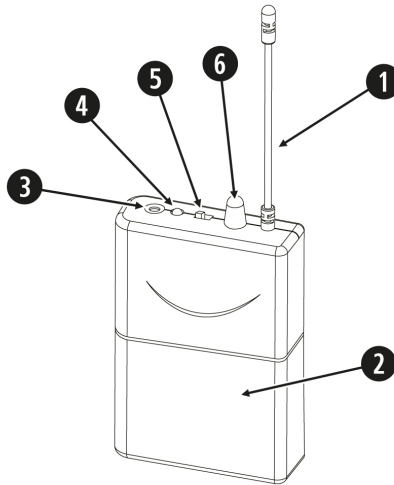

Specification

Comprehensive performance

Carrier frequency	UHF 863.00 - 865.00MHz
Frequency stabilisation	Less than ± 30 ppm
Dynamic range	More than 100dB
Total harmonic distortion	Less than 0.5%
Frequency response	40Hz-15KHz ± 3 dB
Audio output level	Mix type: 0 - ± 400 mV

Fixed receiver

Consume power	100mA
Signal/noise ratio	More than 100dB
Image & spurious rejection	More than 80dB
Border upon channel rejection	More than 80dB
Receiving sensitivity	5dBuV (SINAD=30Db)
De-emphasis	50us

Handing microphone

Transmitter power	30mA
Modulation type	FM
Max deviation	± 40 KHz
Spurious emission	More than 60dB (with carrier)
Battery voltage	1.5 x 1
Continuous usage	Approx. 5 hours

Bodypack microphone

Transmitter power	30mA
Modulation type	FM
Max deviation	25KHz
Spurious emission	More than 40dB (with carrier)
Battery voltage	1.5 x 2
Continuous usage	Approx. 6 hours

Always use high quality branded batteries.

Due to continuous product development, specifications and appearance are subject to change.

